

A470 Transaction Printer:

Setup Guide



1

Unpacking the Printer

Save all packing materials in case you need to repack the printer. To report a printer that was damaged during shipping, see “Contact Information” on the last page of this Guide.

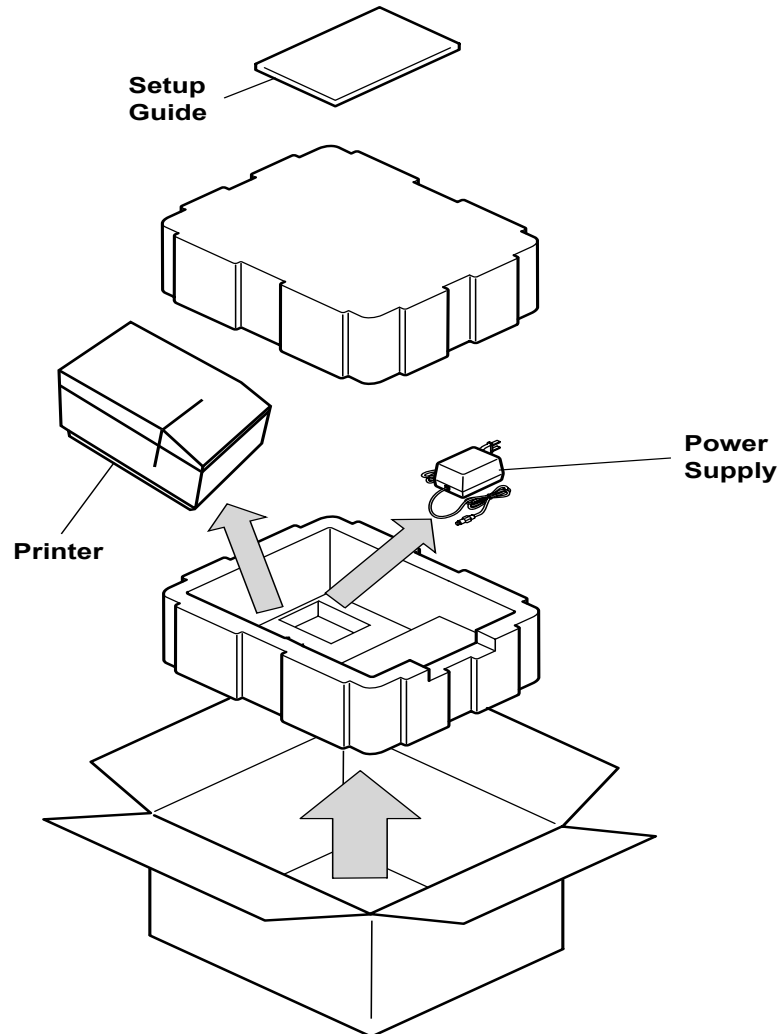

To repack the printer, consult the above illustration and use the original packing materials.

2

Choosing a Location

Place the printer on a level surface on or near the host computer. Leave space to open the cover, change the paper, ribbon cassette, and insert a form from the left side.

The maximum distance from the printer to the host and the power supply is: 50 feet (serial interface).

3

Connecting the Cables

Caution: Be sure the power switch is turned off before connecting cables.

The A470 comes with two communication interfaces, RS-232 Serial and 1284 compliant Parallel. Additionally, the printer is configured with dual cash drawer ports and a Barrel Connector power coupling. The RS-232 interface connector is a RJ45 Female connector and requires a Null Modem Serial cable for standard PC to printer connections. The Parallel Interface uses a DB25 Female connector and requires a standard 1284 compliant DB25 Male to DB25 Female cable for standard PC to printer connections. Two RJ-11 ports provide a unique cash drawer interface capable of running two cash drawers. An external UL listed Class 2 Power Supply provides 24V DC, 2.3A output to the printer. All connectors are located on the back of the printer in the order listed below.

Power Cash Drawer Parallel Serial

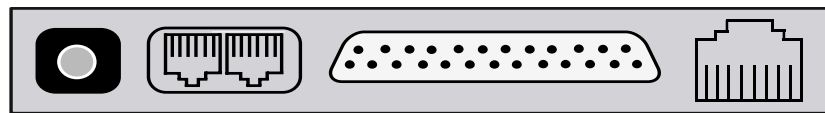

RS-232 Interface Connection



Printer

- RJ-45
- Pin
- 1 Low Paper (TTL)
- 2 RTS
- 3 GND
- 4 TX
- 5 RX
- 6 GND
- 7 Form In (TTL)
- 8 DTR

-
-
-
- ←
-
-

Computer

- | | |
|------|-------|
| DB-9 | DB-25 |
| N/C | N/C |
| 8 | 4 |
| N/C | 1 |
| 2 | 2 |
| 3 | 3 |
| 5 | 7 |
| N/C | N/C |
| 6 | 20 |

Cash Drawer Connectors

Pin	A	B
1	N/C	Solenoid +
2	Solenoid+	N/C
3	Solenoid-	Solenoid-
4	Switch	Switch
5	Switch	Switch
6	N/C	N/C

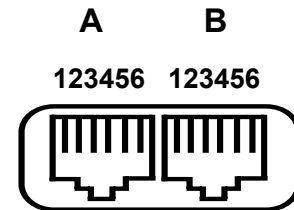

Warning: use of incompatible cables can damage the printer and will void the warranty.

When purchasing a cash drawer for this product please make sure the vendor is aware of the product specifications.

4 Printer Controls

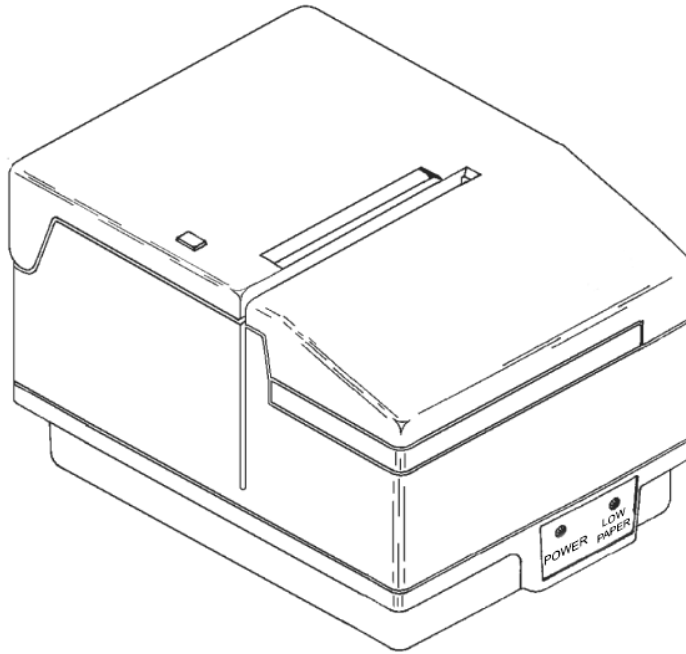

The A470 printer includes the following controls :
Paper feed button used to advance paper
Power switch used to turn the printer on and off

5 Installing the Ribbon Cassette

Raise the printer cover. Leave the printer power on. Lift the old Ribbon Cartridge up and out of the printer and discard. Remove new cartridge from the plastic bag and rotate the advance tab until all slack is removed. Align the new cartridge so the exposed ribbon is between the print head guide and the first silver roller. Lower the cartridge into place. Do not turn the advance tab after the cartridge has been installed. Close the printer cover. For Ribbons call 800-800-6614.

Description	Part Number
Standard Life	
Purple	105109007A
Black	105109009A
Long Life Ribbon	
Purple	105109008A
Black	105109006A

Caution: metal surfaces of printhead may be hot - avoid contact!

6 Loading Paper

Roll paper must be 3.25 inches wide with a maximum diameter of 3.5 inches. Receipt / Journal printers can accommodate 1, 2 or 3 ply paper. Paper and other printer consumables may be purchased from Pertech™ by calling 1-800-800-6614.

Paper Ply	Part Number
One	103292016
Two	103292017
Three	103292021

To load paper the power must be turned ON. Refer to the pictorial paper loading instructions in the lid of the printer. Specific steps may vary depending on the printer configuration. Follow the instructions printed below for your printer model.

Failure to load paper correctly may result in a paper jam. To remove paper that has jammed, it is advisable to:

- 1) Tear off any paper that fed out of the top of the mechanism
- 2) Press downward on the metal release bracket
- 3) While pulling the remaining paper out of the mechanism backwards

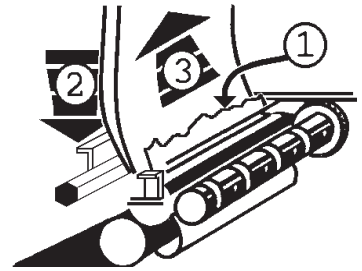

477x Paper Loading Instructions

1 Raise cover and remove the spent roll. Insert the new roll so the paper exits from the bottom of the roll

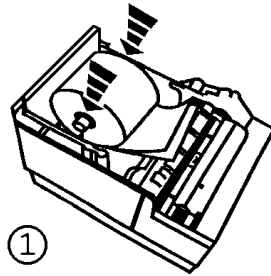

2 Insert the leading edge of the paper into the roller on the black block.

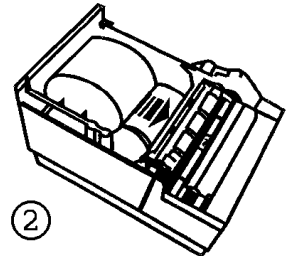

3 Press and hold downward on the green paper loading button...

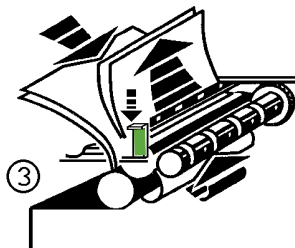

4 ... Until six inches of paper exits from the mechanism.

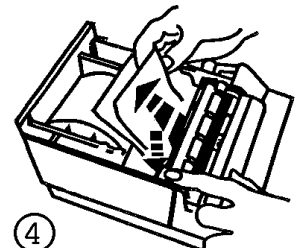

5 Insert the paper through the receipt slot and lower the cover

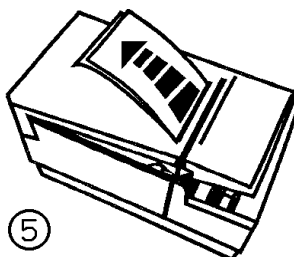

471x paper loading instructions

1. Raise cover and remove the spent roll. Flip the green paper loading chute to the raised position.

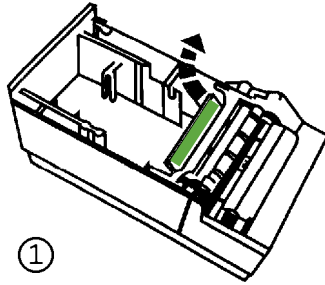

2. Install the new roll so the paper exits from the bottom of the roll.

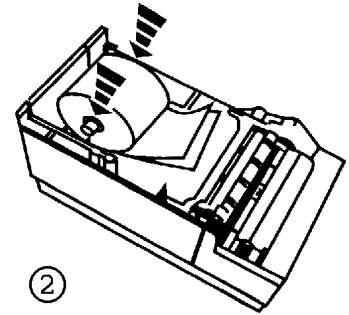

3. Insert the leading edge of the paper into the green loading chute.

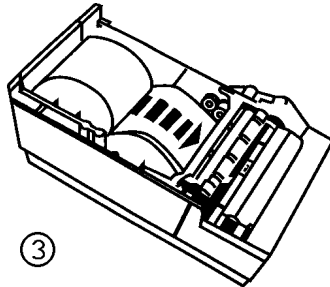

4. Press and hold downward on the green paper loading button ...

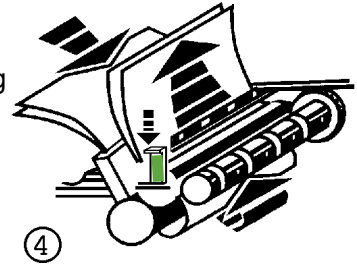

5. ... Until one foot of paper exits from the mechanism

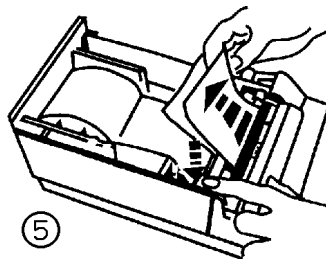

6. Flip the green paper loading chute to the lowered position.

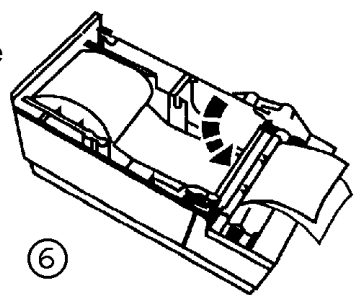

7. Separate the paper plies if more than one ply is used.

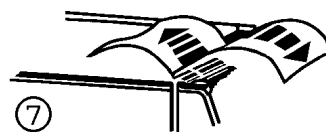

8. Fold and insert the leading edge of the back ply into the rewind spool slot. Rotate as shown to wind up slack.

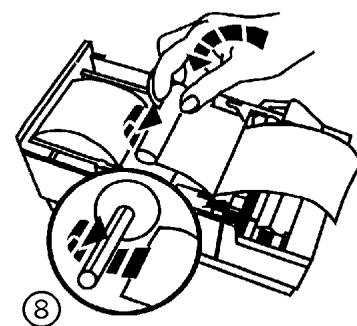

9. Replace the rewind spool in the printer and snap into place.

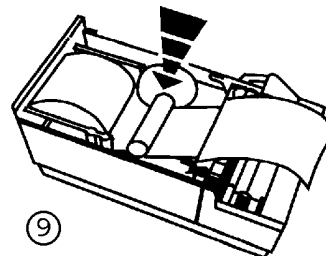

10. Insert the receipt ply through the receipt slot and lower the cover.

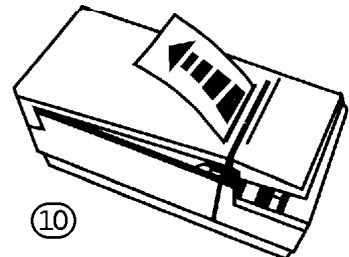

7 Testing and Configuring the Printer

After the printer is set up, you can run a Self Test.

Press and hold the paper feed button and then press the power switch to turn the printer on and start the test. Release the paper feed button after the printing begins and the printer will print the configuration settings. To change the configuration settings two banks of dip switches are located on the bottom of the printer. On the Self Test printout you can see the dip switch configuration for both banks. Below is a table that defines what each dip switch controls. Cycle power for dip switch changes to take effect.

Validation printers will perform a Self Test if a form is detected when the power is turned on.

ON = Closed

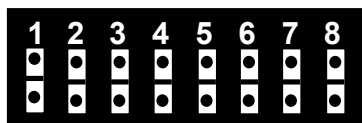

ON

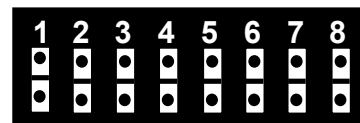

Dip Switch Bank A

Interface	A-1	A-2	A-3
Switch			
19.2k Baud	O	O	O
9600 Baud	O	O	C
4800 Baud	O	C	O
2400 Baud	O	C	C
1200 Baud	C	O	O
600 Baud	C	O	C
300 Baud	C	C	O
Parallel	C	C	C
Journal Line Feed			
Switch	A-4	A-5	
5.3 LPI	O	O	
6.0 LPI	O	C	
6.9 LPI	C	O	
8.0 LPI	C	C	
Auto line feed			
Switch	A-6		
On=<CR>is<LF>	O		
Off=<CR>is<CR>	C		
Serial handshake			
Switch	A-7		
Rts	O		
Xon / xoff	C		
RTS Polarity RS-232 I/F			
Switch	A-8		
-12v (Mark)	O		
+12v (Space)	C		
Fault On Low Paper Parallel I/F			
Switch	A-8		
Yes	O		
No	C		

Dip Switch Bank B

Pitch / Chars. Per Line	B-1	B-2	B-3
Switch			
12.0/33	O	O	O
13.1/36	O	O	C
14.4/40	O	C	O
16.0/44	O	C	C
18.0/50	C	O	O
20.6/57	C	O	C
24.0/66	C	C	O
Not Used	C	C	C
Character Set			
Switch	B-4	B-5	B-6
USA	O	O	O
UK	O	O	C
German	O	C	O
French	O	C	C
Italian	C	O	O
Spanish	C	O	C
Hebrew	C	C	O
Not Used	C	C	C
Validation Clamp			
Switch	B-7		
Closed	O		
Open	C		
Serial Data Format			
Switch	B-8		
8 bits	O		
7 bits	C		

8

Control Code Summary

	ASCII	Hex	Decimal
End of text	ETX	03	3
Three bit status	ENQ ETX	05 03	5 3
Print and line feed	LF	0A	10
Vertical tab	VT	0B	11
Print and carriage return	CR	0D	13
Enable double wide font	SO	0E	14
Disable double wide font	SI	0F	15
Cut Paper	CAN	18	24
Set configuration parameters	EM n	19	25
Reset printer	ESC NUL	1B 00	27 0
Six bit status	ESC ENQ	1B 05	27 5
Cash Drawer "A"	ESC BEL	1B 07	27 7
Cash Drawer "B"	ESC BS	1B 08	27 8
Document Clamp Open	ESC FF	1B 0C	27 12
Self Test	ESC DC3	1B 13	27 19
Document Validation	ESC ETB	1B 17	27 23
Journal Print	ESC SUB	1B 1A	27 26
Document Clamp Close	ESC FS	1B 1C	27 28
Select five dot graphics	{d} ESC GS	1B 1D	27 29
Select character set	ESC !n	1B 21	27 33
Form Eject	ESC A	1B 41	27 65
Download Firmware	ESC B u	1B 42 75	27 66 117
Enable underline print	ESC C	1B 43	27 67
Disable underline print	ESC D	1B 44	27 68
Disable double high font	ESC E	1B 45	27 69
Form In	ESC F	1B 46	27 70
Activate select line	ESC G	1B 47	27 71
Enable double high font	ESC H	1B 48	27 72
Either Form In Sensor	ESC I	1B 49	27 73
Both Form In Sensors	ESC J	1B 4A	27 74
Busy Until Buffer Empty	ESC K	1B 4B	27 75
Clamp Delay	ESC L	1B 4C	27 76
Select pitch	ESC P	1B 50	27 80
Disable upside down print	ESC R	1B 52	27 82
Select print speed	ESC S	1B 53	27 83
Enable upside down print	ESC U	1B 55	27 85
Firmware status	ESC V	1B 56	27 86
Buffered Validate	ESC W	1B 57	27 87
Journal Print	ESC Z	1B 5A	27 90
Buffer Clear	ESC `	1B 60	27 96
Select nine dot graphics	RS	1E	30
Repeat Character	US	1F	31

Federal Communications Commission (FCC) Radio Frequency Interference Statement

Warning

Changes or modifications to this unit not expressly approved by the party responsible for compliance could void the user's authority to operate the equipment.

Note

This equipment has been tested and found to comply with the limits for a Class A digital device, pursuant to Part 15 of the FCC rules. These limits are designed to provide reasonable protection against harmful interference when the equipment is operated in a commercial environment. This equipment generates, uses, and can radiate radio frequency energy and, if not installed and used in accordance with the instruction manual, may cause harmful interference to radio communications. Operation of this equipment in a residential area is likely to cause harmful interference in which case the user will be required to correct the interference at his own expense.

Information to the User

This equipment must be installed and used in strict accordance with the manufacturer's instructions. However, there is no guarantee that interference of radio communications will not occur in a particular commercial installation. If this equipment does cause interference, which can be determined by turning the equipment off and on, the user is encouraged to contact Pertech™ immediately.

Pertech™ is not responsible for any radio of television interference caused by unauthorized modification of this equipment, or the substitution of attachment or connection cables and equipment other than those specified by Pertech™. The correction of interferences caused by such unauthorized modification, substitution or attachment will be the responsibility of the user.

Important Information to the User

In order to ensure compliance with the Product Safety, FCC and CE marking requirements, you must use the power supply, power cord, and interface cable which were shipped with this product or which meet the following parameters:

Power Supply

UL Listed, Class II power supply, input rated 100-240 Vac, 1.5/0.8 A, 50/60 Hz, output rated 24 Vdc, 2.3 A, Max power 55W.

Use of this product with a power supply other than the Pertech™ power supply will require you to test this power supply and the Pertech™ printer for FCC and CE mark certification.

Interface Cable

A shielded (360 degree) interface cable must be used with this product. The shield must be connected to the frame or earth ground reference at each end of the cable.

Use of a cable other than the described here will require that you test this cable with the Pertech™ printer and your system for FCC and CE mark certification.

Power cord

A UL listed, detachable power cord must be used for this product. For applications where the power supply module may be mounted on the floor, a power cord with Type SJT marking must be used. For applications outside the US, Power cords which meet the particular country's certification and application requirements should be used.

Use of a power cord other than described here may result in a violation of safety certifications which are in force in the country of use.

Industry Canada (IC) Radio Frequency Interference Statement

This Class A digital apparatus meets all requirements of the Canadian Interference-Causing Equipment Regulations.

Cet appareil numérique de la classe A respecte toutes les exigences du Règlement sur le matériel brouilleur du Canada.

Disclaimer

Information in this document is subject to change without notice. Consult your Pertech™ sales representative for information that is applicable and current. Pertech™ reserves the right to improve products as new technology, components, software and firmware become available.

No part of this document may be reproduced or transmitted in any form or by any means, electronic or mechanical, for any purpose without the express written permission of Pertech™.

Copyright

Copyright © 2004 by Pertech Resources, Inc.

Riverton, Wyoming USA

All rights reserved. Printed in USA. Confidential, Unpublished. Property of Pertech™.

Trademarks

Pertech is a trademark of Pertech Resources, Inc. Other trademarks and registered trademarks are the property of their respective holders.

Contact Information

Documentation, Warranty & Technical Support : Call: 800-800-6614

www.pertechresources.com

